

ISRAEL RAILWAYS LTD

INFRASTRUCTURE DIVISION

TRACK AND RIGHT OF WAY DEPARTMENT

**Technical Specifications
for
Manufacture and Supply of
T-Head Bolt with Square
Neck M24x100 with Nut M24
and Double Spring Washer**

No. E-01-0036.1

~~March~~July 2017



*T-Head Bolt with Square Neck M24*100 with Nut M24 and Double Spring Washer*

No. E-01-0036 March 2017

AMENDMENTS:

This technical specification differs from version No. E-01-0036 March 2017 as follows:

- i. Section 2.12 has been added;**
- ii. Attachment A has been revised;**
- iii. The technical specification has been editorially revised.**

CONTENTS

1.	SCOPE	<u>34</u>
2.	T-HEAD BOLT M24x100 WITH SQUARE NECK BOLT AND NUT	<u>35</u>
3.	DOUBLE SPRING WASHER	<u>45</u>
4.	TESTS AND INSPECTION CERTIFICATES	<u>56</u>
5.	DRAWING	<u>56</u>
6.	MARKING	<u>56</u>
7.	LIST OF DOCUMENTS TO BE SUBMITTED WITH PROPOSAL	<u>56</u>
8.	LIST OF DOCUMENTS TO BE SUBMITTED WITH EVERY DELIVERY	6
9.	PACKING	<u>67</u>
10.	WARRANTY	<u>7</u>
ATTACHMENT A	T-HEAD BOLT WITH SQUARE NECK M24X100	8
ATTACHMENT B	NUT M24	9
ATTACHMENT C	DOUBLE SPRING WASHER	10

*T-Head Bolt with Square Neck M24*100 with Nut M24 and Double Spring Washer*

No. E-01-0036 March 2017

1. **SCOPE**

This technical specification pertains to the manufacture and supply requirements of T-Head bolt M24x100 with nut and double spring washer to be used in the Israel railway permanent way.

2. **T-HEAD BOLT M24x100 WITH SQUARE NECK BOLT AND NUT**

- 2.1 The T-head bolts material quality manufacturing, tests and acceptance conditions shall be according UIC 864-2.
- 2.2 The T-head bolts shall be manufactured from single piece, without welding.
- 2.3 The T-head bolts dimensions and tolerances shall be in accordance with drawings in attachments A and B.
- 2.4 The T-head bolts steel category shall be at least 8.8 according UIC 864-2.
- 2.5 The T-head bolts tensile strength shall be greater than 830 N/mm².
- 2.6 The T-head bolts elongation shall be greater than 12%.
- 2.7 The nuts shall have hexagon shape with steel grade of quality of the T-head bolts or with the nearest grade below.
- 2.8 The T-head bolts and nut shall be rust protected, and must be free from any trace of grease, paint, etc. before the rust protection.
- 2.9 The complete surface of the T-head bolts and nut shall be suitably re-burred. Care shall be taken to ensure that the re-burring doesn't give rise to any tearing of the metal or leave any roughness on the contact surfaces.
- 2.10 The shanks shall be perfectly smooth and straight, without flow or cracks. The head shall be clearly cut and correctly centered in relation to the shanks.

The same parameters shall be applying in the case of the nuts.

In additional, no folding of the metal shall occur on the head at the point of junction with the shank. The contact surfaces of the T-head bolts and nuts must be level and perpendicular in relation to the longitudinal axis.

2.11 The threads must be clean, uniform and complete. If the threads of the T-head bolts and nuts are stripped or if there is a lack of material, they shall not be accepted.

2.12 **The T-Head Bolt point shall have permanent marking, to indicate the T-Head Bolt head position (see attachment A).**

~~2.11~~

3. **DOUBLE SPRING WASHER**

- 3.1 The double spring washers shall be manufactured from spring steel. The double spring washer quality manufacturing, tests and acceptance conditions shall be according UIC 864-3 O: 1982.
- 3.2 The double spring washers dimensions will be in accordance with drawing in attachment C.
- 3.3 The double spring washers steel category shall be 38S7.
- 3.4 Chemical composition of the raw material:
 - $0.35 \leq C\% \leq 0.42$,
 - $1.5 \leq Si\% \leq 1.8$,
 - $0.5 \leq Mn\% \leq 0.8$,
 - $S\% \leq 0.045$,
 - $P\% \leq 0.045$.
- 3.5 The double spring washers tensile limit elasticity shall be greater than 1030 N/mm^2 .
- 3.6 The double spring washers tensile strength shall be greater than 1180 N/mm^2 .
- 3.7 The double spring washers elongation at fracture shall be greater than 6%.
- 3.8 The double spring washers shall be manufactured by helicoidal coiling of steel bar. The spiral must be entirely regular.
- 3.9 The conditions of manufacture of the double spring washers obtained from bars of the same casting must be identical.
- 3.10 The internal and external surfaces of the double spring washers of rectangular section shall be parallel to the coiling axis when the double spring washer is in flatted position; the section shall be slightly rounded at the edges.
- 3.11 The double spring washers surface shall be knurled.
- 3.12 When fully compressed, the coils must be fully superimposed one above the other. The end surfaces shall then be situated on the plane running through the axis of the coiling spiral.
- 3.13 The double spring washers shall be hardened and tempered the hardness shall be 430-515 HV 30.

*T-Head Bolt with Square Neck M24*100 with Nut M24 and Double Spring Washer*

No. E-01-0036 March 2017

3.14 The double spring washers shall be regular and clean, and free from superficial cracks, flaws, burrs, and deficiency in metal, folds, or any other defects likely to affect the use for which they are intended. The outside surface, in particular, must be smooth and free from burrs.

3.15 The double spring washers shall be rust protected, all surfaces shall be thoroughly covered.

4. **TESTS AND INSPECTION CERTIFICATES**

4.1 For every order of T-head bolts with nuts and washers, the manufacturer shall submit testing and inspection certificates for dimensions, strength, surface and structure. (in accordance with UIC 864-2; UIC 864-3; and this technical specifications)

4.2 For every order of T-head bolts with nuts and washers the manufacturer shall submit certificates of rust protection.

5. **DRAWING**

5.1 The manufacturer shall submit, together with his proposal, a complete set of manufacturing technical drawings set, based on this technical specification with dimensions, tolerances and material main characteristics, coating description, etc.

6. **MARKING**

6.1 Each component shall be inscribed with at least the following marks:

- supplier mark,
- last two figures of the year of manufacture,
- product identification type.

7. **LIST OF DOCUMENTS TO BE SUBMITTED WITH PROPOSAL**

7.1 The manufacturer shall submit quality management system process for the components manufacturing and rust protection in accordance with all the requirements in this technical specification based on ISO 9001.

7.2 The manufacturer shall submit to ISR certificate that the metallic materials comply with the requirements in this technical specification.

7.3 The manufacturer shall submit all the manufacturing technical drawings.

8. **LIST OF DOCUMENTS TO BE SUBMITTED WITH EVERY DELIVERY**

*T-Head Bolt with Square Neck M24*100 with Nut M24 and Double Spring Washer*

No. E-01-0036 March 2017

8.1 Each delivery shall be received with manufacturer certificate that each component was manufactured according to the requirements of this technical specification and technical drawings submitted. Testing certificates of dimensions, strength, surface and structure shall be submitted, including rejected components and the reasons for rejection.

9. **PACKING**

9.1 The manufacturer shall screw the T-head bolt together with the double spring washer and the nut (as one unit), and pack 50-100 units in a strong sack.

The sacks will be put in a wooden box.

The gross weight of a wooden box shall not exceed 1 ton.

The wooden boxes shall be tightened by metal bands, and shall be fastened to one another with plastic nylon. They shall be tied to wooden platform by plastic bands.

The dimensions of the wooden boxes shall enable maximum effective storage capacity in containers.

It shall be possible to put at least 3 wooden boxes one on the other.

9.2 Each sack shall be labeled with the following details:

- number of units per sack;
- weight of each sack.

9.3 Each package of wooden boxes shall be labeled with the following details:

- component names and types;
- production batch numbers;
- date of manufactures;
- component barcodes;
- component quantity in box;
- gross and net weight;
- manufacturer recognition numbers or names;
- ISR recognition numbers;
- ISR order number;
- ordinal number on the packing list.



*T-Head Bolt with Square Neck M24*100 with Nut M24 and Double Spring Washer*

No. E-01-0036 March 2017

The labeling shall be with black letters and shall be on 3 spots on the package (one on top of the package and the two others on the sides).

*T-Head Bolt with Square Neck M24*100 with Nut M24 and Double Spring Washer*

No. E-01-0036 March 2017

ATTACHMENT A - T-HEAD BOLT WITH SQUARE NECK M24x100

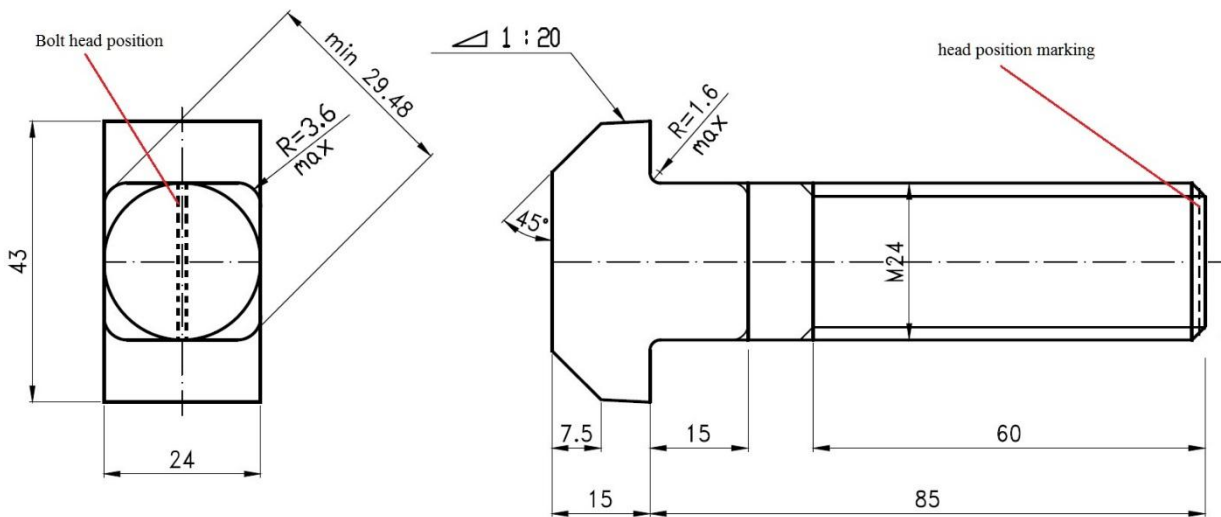

ATTACHMENT B-NUT M24

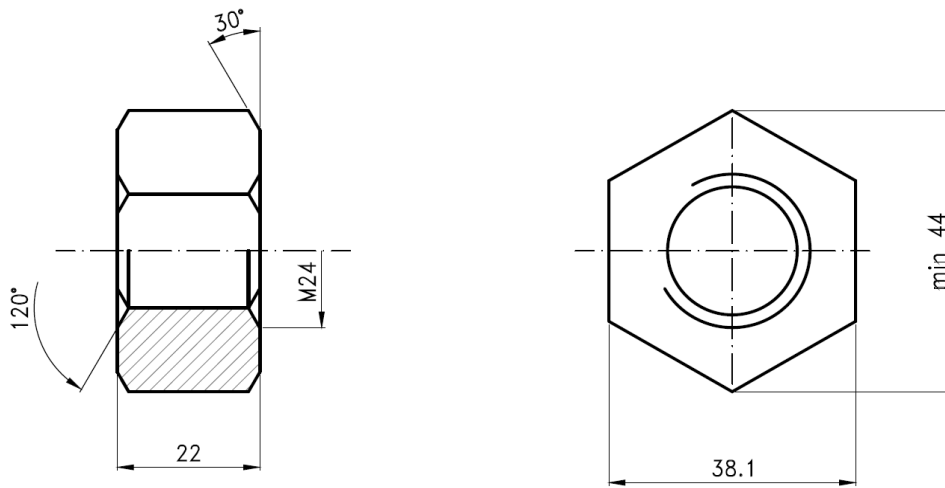

ATTACHMENT C – DOUBLE SPRING WASHER

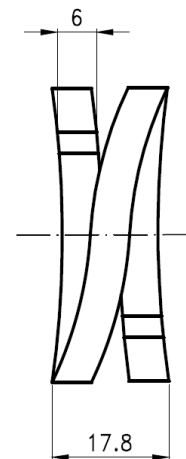
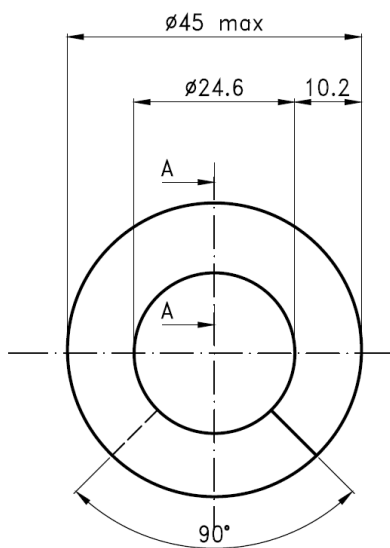

A-A

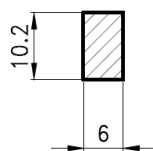

Steel Category 38S7

Manufacture in accordance with UIC 864-3