

ISRAEL RAILWAYS LTD
INFRASTRUCTURE DIVISION
TRACK AND RIGHT OF WAY DEPARTMENT

Technical Specifications
for
Manufacture and Supply
of
RAILS:

- **60E2 Profile and R260 Grade**
- **54E1 Profile and R260 Grade**
- **50E6 Profile and R260 Grade**

No. E-01-0041.2

July 2019



AMENDMENTS:

This technical specification differs from version No. E-01-0041.1 February 2019 as follows:

- i. Section 4.7 has been revised;
- ii. The technical specification has been editorially revised.



CONTENTS

1. SCOPE.....	3
2. REFERENCE DOCUMENTS.....	3
3. DEFINITIONS.....	3
4. GENERAL REQUIREMENTS	4
6. QUALIFYING TESTS.....	9
7. ACCEPTANCE TESTS	9
8. LABORATORY CERTIFICATES	13
9. INSPECTION BY A REPRESENTATIVE OF ISR.....	14
10. LIST OF DOCUMENTS TO BE SUBMITTED WITH BIDDER'S PROPOSAL	15
11. LIST OF DOCUMENTS TO BE SUBMITTED WITH EVERY ORDER	16
12. PACKING.....	16
TECHNICAL APPENDIX A –FISHPLATE BOLT HOLE POSITION – IN THE RAIL WEB	17
TECHNICAL APPENDIX B – COLOR MARK ON RAIL.....	20



1. **SCOPE**

These technical specifications describe the requirements for the manufacture and supply of:

Rails with different Rail Profile: 60E2; 54E1 and 50E6 and Steel Grade - R260 ("**The Rail/(s)**") for use on Railway tracks.

2. **REFERENCE DOCUMENTS**

EN13674-1	Track - Rail - Part 1: Vignole Railway Rails 46 kg/m and above;
ISO/IEC17025	General requirements for the competence of testing and calibration laboratories;
ISO9001	Quality management systems - Requirements;
EN10163-1	Delivery requirements for surface condition of hot-rolled steel plates, wide flats and sections - Part 1: General requirements;
EN10168	Steel products – Inspection documents
EN10204	Metallic products - Types of inspection documents

Note – the latest edition of the referenced document should be considered

3. **DEFINITIONS**

3.1.	ISR	Israel Railways LTD.
3.2.	The Inspector	shall have the meaning assigned to it in Section 9.1 aforementioned;
3.3.	The Laboratory	shall have the meaning assigned to it in Section 8 aforementioned;
3.4.	The Rail/(s)	shall have the meaning assigned to it in Section 1 aforementioned;
3.5.	Rail Profile 50E6	as defined in EN13674-1, Annex A, figure A.13;
3.6.	Rail Profile 54E1	as defined in EN13674-1, Annex A, figure A.15;
3.7.	Rail Profile 60E2	as defined in EN13674-1, Annex A, figure A.24;

3.8. **Steel Grade R260** as defined in EN13674-1, section 5;

4. **GENERAL REQUIREMENTS**

4.1. Unless otherwise and to the extent specified hereafter, the Rails shall conform in every aspect with the latest edition of EN13674-1.

4.2. The 60E2 Rail Profile, dimensions, properties and linear masses shall conform with the requirements of EN13674-1, Annex A - figure A.24.

The 54E1 Rail Profile, dimensions, properties and linear masses shall conform with the requirements of EN13674-1, Annex A - figure A.15.

The 50E6 Rail Profile, dimensions, properties and linear masses shall conform with the requirements of EN13674-1, Annex A - figure A.13.

4.3. The Rails harness range of Steel Grade R260 shall conform with the requirements of EN13674-1, section 5 - table 1.

4.4. The manufacture process shall be continuous casting, and no other process shall be approved.

4.5. The Rails Chemical Composition and Mechanical Properties shall conform with the requirements of EN13674-1, table 5a; table 5b.

- Table 5a – Chemical Composition and Mechanical properties:

Steel Grade		% by mass										10 ⁻⁴ % (ppm) by mass max.	Tensile strength	Elong ation	Hardness of the Rail running surface centerline HBW
Steel Name	sample	C	Si	Mn	P max.	S max.	Cr	Al max.	V max	N max	O	H	Rm min. MPa	A min. %	
R260	Liquid	0.62 to 0.80	0.15 to 0.58	0.70 to 1.20	0.025	0.025	≤0.15	0.004	0.030	0.009	20	2.5			
	Solid	0.60 to 0.82	0.13 to 0.60	0.65 to 1.25	0.030	0.030	≤0.15	0.004	0.030	0.010	20	2.5	880	10	260 to 300

- Table 5b – Maximum Residual Elements, % by mass:

Steel Name	Mo	Ni	Cu	Sn	Sb	Ti	Nb	Cu + 10 Sn	others
R260	0.02	0.10	0.15	0.030	0.020	0.025	0.01	0.35	0.35 (Cr + Mo + Ni + Cu + V)

4.6. The Rails Profiles: 60E2 and 54E1 tolerances shall conform with the profile class X, and straightness, surface flatness and twist tolerances shall conform with Class A, and

The Rails Profile 50E6 tolerances shall conform with the profile

class Y, and straightness, surface flatness and twist tolerances shall conform with class B, all in compliance with EN13674-1, section 9.2, table 7, and table 8:

- **Table 7 - Profile tolerances**

Reference points (EN13674-1, figure E.1)			60E2 and 54E1 Profile class (tolerances in [mm])	50E6 Profile class (tolerances in [mm])
Location/ property		symbol	X	Y
Height of Rail ^a	< 165 [mm]	*H	± 0.5	+0.5 -1.0
	≥ 165 [mm]		± 0.6	+0.6 -1.1
Crown profile - Class A straightness		*C	+ 0.6 - 0.3	N/A
Crown profile - Class B straightness			N/A	± 0.6
Width of Rail head		*WH	± 0.5	+0.6 -0.5
Rail asymmetry		*As	± 1.2	± 1.2
Height of fishing	< 165 [mm]	H	± 0.5	± 0.5
	≥ 165 [mm]		± 0.6	± 0.6
Web thickness		*WT	+ 1.0 - 0.5	+1.0 -0.5
Width of Rail foot		*WF	± 1.0	+1.5 -1.0
Foot toe thickness		*TF	+ 0.75 - 0.5	+ 0.75 - 0.5
Foot base concavity			0.3 max.	0.3 max.

^a The total height variation over any of The Rail length shall not be greater than 1 [mm] for Rails < 165 mm and 1.2 [mm] for The Rails ≥ 165 [mm].

- Table 8- Straightness, surface flatness and twist tolerances -- Class A:

Location/Dimensional properties		50E6		60E2 and 54E1		
		Class B		Class A		
		d	L	d	L	
BODY	Vertical flatness V	≤0.4 [mm]	3 [m]	≤0.3 [mm]	3 [m]	
		and		and		
		≤0.3 [mm]	1 [m]	≤0.2 [mm]	1 [m]	
	Horizontal flatness H	≤0.6 [mm]	1.5 [m]	≤0.45 [mm]	1.5 [m]	
ENDS	End "E"	1.5 [m]		2 [m]		
	Vertical straightness	≤0.5 [mm]	1.5 [m]	≤0.4 [mm]	2 [m]	
		and		and		
		≤0.3 [mm]	1 [m]			
e ≤0.2 [mm]		e ≤0.2 [mm]				
Horizontal straightness		≤0.7 [mm]	1.5 [m]	≤0.6 [mm]	2 [m]	
				and		
				≤0.4 [mm]	1 [m]	
OVERLAP	Length of overlap	1.5 [m]		2 [m]		
	Vertical flatness V	≤0.4 [mm]	1.5 [m]	≤0.3 [mm]	2 [m]	
	Horizontal flatness H	≤0.6 [mm]	1.5 [m]	≤0.6 [mm]	2 [m]	
SWEEP (whole The Rail)	Upsweep and down sweep	10 [mm]		10 [mm]		
TWIST	Whole The Rail	max. gap of 2.5 [mm]				In accordance with EN13674-



			1, section 9.2.2, and figure 10
	End (1 [m])	Max. rotational twist of 0.2° and max. relative twist of 0.0035 x c	In accordance with EN13674-1, section 9.2.2, and figure 11

- 4.7. The Rails shall be supplied in length of 18 meter. The Rails length tolerances shall conform with the requirements of EN13674-1, Table 9.

ISR may request that the Rails shall be supplied in length of 18.25 and/or 24.6 meter (it will be requested in advance and be noted in the purchase order).

- 4.8. Each Rails shall be with drilled holes at each of its two ends with a 28 [mm] diameter. The center of the holes shall be at a height, and at a length from The Rail end, as described in Technical Appendix A – Fishplate Bolt Hole Position in The Rail Web.

The drilled holes, and The Rail ends shall be deburred.

The size and location tolerances of drilled holes and the squareness tolerance on The Rail ends shall conform with the requirements of EN13674-1 Table 9.

- Table 9 – Drilling and cutting tolerances:

No.	Dimensional requirement	Tolerance
1	Drilling Diameter ≤ 30 [mm] Centering and positioning of the holes vertically and horizontally	± 0.5 [mm] The horizontal position of the holes shall be checked using a gauge as specified in EN13674-1, Figure E.12. The diameter of the pins for horizontal and vertical clearances shall be smaller than the diameter of the holes by: <ul style="list-style-type: none"> • 1 [mm] for holes less than or equal to 30 [mm] in diameter; The distances between the center lines of the pins and the stop shall be equal to the nominal distances from the center line of the holes to the end of The Rail. The gauge pins shall be able to enter the holes at the same time while the stop is touching the end of The Rail. The vertical centering of the holes shall be checked using a gauge as specified in EN13674-1, Figure E.13. The side of the hole, left or right, shall be determined by proceeding from the side with the relief markings.

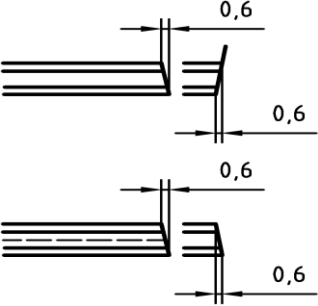
2	Squareness of ends	<p>0.6 [mm]</p> 
3	<p>Length ^a</p> <p>-both ends drilled</p> <p>≤ 24 [m]</p>	<p>± 3 [mm]</p>
<p>^a The given Rail lengths apply for +15 °C. Measurements made at other temperatures shall be corrected to take into account expansion or contraction of the Rail.</p>		

- 4.9. The Rails identification branding and stamping shall conform with EN13674-1, section 7.4. In addition, The Rails Manufacturer name shall be brand on the rail web.
- 4.10. The Rails shall be identified with a color marks, 3 [m] from The Rail end on each end of The Rail, in accordance with Technical Appendix B.
- 4.11. The Rails shall be marked with long term white color marked on the Rail Head, 9 [m] from The Rail end, (The Rail central of mass, which enable safe lifting with ISR crane).
- 4.12. The Rails manufacture process shall conform with the requirements of EN13674-1, section 7.
- 4.13. The Rails Manufacturer shall specify any bloom slow cooling or isothermal treatment process used to demonstrate compliance with the requirements of EN13674-1, sections - 8.1 and 9.1.3.2, a statement shall be submitted.

5. **QUALITY CONTROL AND QUALITY ASSURANCE PROCEDURES PLAN**

- 5.1. The Rails shall be manufactured under a comprehensive quality control management system, which shall ensure confidence consistently compliance in the conformity of the finished product, including documented evidence, all in accordance with the requirements of EN13674-1, ISO9001, EN10168 and the technical specifications to provide assurance of product safety in track.

The Rails Manufacturer production control management system procedures, and ISO9001 certificate shall be submitted.

- 5.2. The calibration rails shall be used to test the Ultrasonic test system and the NDT automatic system at production speed at the beginning and once every 8 [hours] of testing a particular profile. calibration certificates carried out by The Laboratory shall be submitted with The Bidder proposal, and shall be submitted to The Inspector on request.

6. **QUALIFYING TESTS**

- 6.1. The Rails Qualifying Tests shall be carried out in accordance with the requirements of EN13674, section 8.
- 6.2. All Qualifying Tests shall be carried out on the Rail with 60E1 or 60E2 profile, by The Laboratory, which is certified following with the requirements of section 8, hereinafter.
- 6.3. A full Qualifying Tests report, from the last five years, carried out and signed by The Laboratory, approving the fulfillment of The Rail Grade R260 manufacture, with the requirements of EN13674-1, sections - 8.2; 8.3; 8.4; 8.5; 8.7; 8.8; and 8.9, and this technical specifications, shall be submitted.
- 6.4. The management calculations procedures of tensile strength and elongation in accordance with EN13674-1 section 8.7, shall be submitted.
- 6.5. The Laboratory shall carry out all the Acceptance Tests specified in EN13674-1, section 9.1, and The Rails Manufacturer shall submit a complete set of results for these tests as part of the Qualifying Test Report (conform with the requirements of EN13674-1, section 8.9).
- 6.6. The Qualifying Test samples and pieces shall conform with the requirements of EN13674-1, sections - 8.1.3; 8.1.4; 8.1.5; 8.2.1; 8.3.2; 8.3.3; 8.4.2; 8.4.3; 8.5.2; 8.5.3; 8.8; and 9.1.2.

7. **ACCEPTANCE TESTS**

- 7.1. All The Rails, which will be supplied shall conform with the requirements of EN13674-1, section 9.
- 7.2. The Acceptance Tests shall be carried out, during The Rails manufacture process, by The Laboratory, in accordance with the requirements of EN13674-1, section 9, and EN10168, at the frequencies specified in EN13674-1, table 4.

• Table 4 – Testing frequency –

Test	Comply with the requirements of EN13674-1 section	Steel Grade
		R260
Chemical composition	9.1.3	One per heat
Hydrogen	9.1.3.2	One per heat (2 tests from first heat in sequence)
Total oxygen	9.1.3.3	One per sequence ^a
Decarburization	9.1.5	One per 1,000 [ton] or part thereof ^{a, b}
Oxide cleanness	9.1.6	One per sequence ^b
Sulfur print	9.1.7	One per 500 [ton] or part thereof ^{a, b}
Hardness	9.1.8	One per heat ^{a, b}
Tensile	9.1.9	one test per 2,000 [ton]
^a Samples shall be taken at random but only The Rails from blooms outside the mixing zone between heats when continuously cast in sequence.		
^b Samples shall be cut after rolling.		

In addition, the following tests shall be carried out and conform with the following quality requirements:

7.2.1. MECHANICAL PROPERTIES AND CHEMICAL COMPOSITION TESTS

The Rails mechanical properties and chemical composition inspection tests results shall conform with the requirements of EN13674-1, table 5(a); and table 5(b), and in additional EN 10204, Type 3.1; or Type 3.2, these results shall be submitted.

7.2.2. TENSILE STRENGTH AND ELONGATION TEST

The tensile strength and elongation test results in compliance with the management calculations procedures in accordance with the requirements of EN13674-1, sections - 8.7 and 9.1.9, shall be submitted.

7.2.3. DIMENSIONS TOLERANCES

The Rails nominal dimensions shall conform with EN13674-1, Annex A – figures: A.24 for The 60E2 Rail Profile; A.15 for The 54E1 Rail Profile; A.13 for The 50E6 Rail Profile.

The actual dimensions on any of The Rails shall conform with the tolerances, in accordance with EN13674-1, table 7.

The Rails flatness tests shall be carried out automatically. The tolerances for straightness, surface, flatness and twist shall conform with the requirements of EN13674-1, table 8.

The Rail twist shall not exceed 2.5 [mm], and the rotation twist at the end meter of The Rail, measured by the gauge instrument specified in EN13674-1, figure 11, shall not exceed 0.2°.

The size and location of the drilled holes, and The Rail ends squareness, and The Rail lengths shall conform with the tolerances, specified in EN13674-1, table 9.

7.2.4. INTERNAL QUALITY

Internal defects

The Internal Quality Test shall be carried out on 100% of The Rails, by an automatic continuous ultrasonic process ensuring that the entire length and the cross-sectional area is inspected with particular emphasis on The Rail ends.

The Rail ends, which the automatic continuous ultrasonic test system cannot cover, separate ultrasonic procedure shall be carried out on each of The Rail ends, or these Rail ends shall be cut off.

The technique used shall ensure that the minimum cross-sectional area covered by the inspection is no less than:

- (a) 70% of the head;
- (b) 60% of the web;
- (c) The area of the Rail foot specified in EN13674-1, Figure 15.

The Rail head shall be tested from both sides and from the Rail running surface.

The method of inspection shall be in accordance with EN13674-1, section 9.4.1.3, and 9.4.1.4.

A detailed description of the ultrasonic test method, including the separate ultrasonic procedure or The Rail end cut off process, and in additional the locations and dimensions of the artificial defects in The Rail head, web and foot, shall be submitted.

7.2.5. SURFACE QUALITY

7.2.5.1. **Protrusions**

Protrusions on The Rail running surface and/or the underside of The Rail foot, and/or any protrusions affecting the fit of the fishplate at less than 1 [m] from the extremity of The Rail shall not be permitted.

7.2.5.2. Hot marks, seams

The depth of hot marks and seams, in accordance with EN10163-1, shall not exceed:

- 0.35 [mm] for The Rail running surface;
- 0.5 [mm] for the rest of The Rail.

7.2.5.3. Guide marks

There shall not be more than two longitudinal guide marks, to the depth limits specified above and to the width of maximum 4 [mm], with width to depth ration of minimum 3:1, at any point along The Rail length, but no more than one of these guide marks shall be on The Rail running surface.

7.2.5.4. Hot formed marks

Hot formed marks originating from the vicinity of the mill rolls on The Rail crown - a maximum of 3 per 40 [m] shall be permitted.

7.2.5.5. Cold marks

Longitudinal or transverse cold formed scratches discontinuity depth shall not be larger than:

- 0.3 [mm] for The Rail running surface and underside of foot;
- 0.5 [mm] for the rest of The Rail.

7.2.5.6. Surface Microstructural Damage

Any sign of surface microstructure damage resulting in martaensite or white phase shall be dressed or The Rail shall be rejected. The dressed area shall be proved by suitable hardness testing. The hardness shall not be 50 HBW greater than the surrounding material.

7.2.5.7. Surface imperfections

Each of The Rails shall be inspected by NDT (Non-Destructive Testing) automatic system, for surface imperfections, on the following faces along the entire Rail length:

- on the underside of The Rail foot;
- on The Rail head (running surface and sides).

All The Rails shall conform with the acceptance criteria specified in EN13674-1, section 9.4.2.1., and dressing of imperfections shall conform with the requirements of EN13674-1, section 9.4.2.3.

the NDT automatic system shall be able to detect artificial imperfections on the underside of the foot with sizes in accordance with the requirements of EN13674-1, table 10, with ± 0.1 [mm]

- table 10 – Dimensions of test imperfections,

Depth [in mm]	Length [in mm]	Width [in mm]
1.0	20	0.5
1.5	10	0.5

An edge loss for the NDT automatic technique is permitted for the extreme 5 [mm] of the flat portion of the foot width at each side.

A detailed description of the automatic NDT test method, including drawing showing the locations and dimensions of the artificial defects in The Rail head and foot shall be submitted.

7.2.5.8. **Dressing of surface imperfections**

Imperfections exceeding the limits specified in EN13674-1, sections - 9.4.2.1.(a), and 9.4.2.1.(b) shall be dressed out. Any protrusions affecting the fit of the fishplate in accordance with EN13674-1, section 9.4.2.1.(a) shall be dressed to shape.

The Rail microstructure shall not be affected dressing operation.

The depth of dressing shall not be larger than:

- 0.35 [mm] for The Rail running surface;
- 0.5 [mm] for the rest of The Rail.

Dressing of no more than three defects within a length of 10 [m] of The Rail and, over the whole length, a maximum of one defect per 10 [m] of The Rail length shall be permuted. After dressing The Rail Profile tolerances shall be in accordance with EN13674-1, table 7, and The Rail flatness tolerances shall be in accordance with EN13674-1, table 8.

- 7.3. The Acceptance Test samples and pieces shall conform with the requirements of EN13674-1, sections - 9.1.2; 9.1.3; 9.1.5; 9.1.6; 9.1.7; 9.1.8; and 9.1.9.

- 7.4. The complete set of results for All the Acceptance Tests required in section 7.2 aforementioned, for each Israel Railways ("ISR") purchase order, shall be submitted.

8. **LABORATORY CERTIFICATES**

- 8.1. The Laboratory, that is carrying out the Qualifying Tests and Acceptance Tests is certifying with at least the following

certifications:

- The Laboratory certified in accordance with ISO/IEC17025 in the field of steel quality testing;

or

- The Laboratory accredited by national laboratory accreditation authority in the field of steel quality testing;

8.2. The Laboratory certificate, include its appendixes, approving its compliance with the requirements of section 8.1, above, shall be submitted.

9. **INSPECTION BY A REPRESENTATIVE OF ISR**

9.1. The ISR technical team and/or an inspection body appointed by the ISR ("**The Inspector**") shall inspect the manufacture processes, the Qualifying Tests results, and Acceptance Tests process and results of The Rails, as specified in EN13674-1, and in this technical specification.

9.2. It is The Rails Manufacturer's responsibility to guarantee dimensional accuracy and to ensure that the inspection is carried out with the appropriate measuring instruments.

9.3. The Rails Manufacturer shall be responsible to coordinate inspection process time table with The Inspector in accordance to the delivery date defined in the purchase order.

9.4. The Rails Manufacturer shall extend, to The Inspector, all necessary assistance and cooperation, and shall give access to all test records, calibrations and calculations that contribute to the final results.

9.5. All the gauge/measuring instruments for manufacture verification and inspection of The Rails shall be made available by The Rails Manufacturer to The Inspector on request.

9.6. The Rails Manufacturer shall provide, for every purchase order, all Acceptance Tests results to The Inspector for approval.

9.7. The Acceptance Tests Report and Certificates signed by The Rails Manufacturer, and The Laboratory shall be submitted.

9.8. The Qualifying Tests Report and Certificates signed by the Laboratory shall be made available to The Inspector on request.

9.9. The Calibration Certificates of the gauge/measuring instruments

signed by the Laboratory shall be made available to The Inspector on request.

10. **LIST OF DOCUMENTS TO BE SUBMITTED WITH BIDDER'S PROPOSAL**

- 10.1. A statement that specify any bloom slow cooling or isothermal treatment process used to demonstrate compliance with the requirements of EN13674-1, section 9.1.3.2. (section 4.13)
- 10.2. The Rails Manufacturer shall submit Manufacturer production control system procedures which are conforming with EN13674-1 and ISO9001. (section 5.1).
- 10.3. The Rails Manufacturer shall submit its ISO9001 certificate. (section 5.1).
- 10.4. The calibration certificates, carried out by The Laboratory, on the calibration rail/(s) used to test the Ultrasonic test system and the NDT automatic system at production speed. (section 5.2).
- 10.5. A full Qualifying Tests Report, from the last five years, carried out and signed by The Laboratory, approving the fulfillment of The Rail Grade R260 manufacture with the requirements of EN13674-1, sections - 8.2; 8.3; 8.4; 8.5; 8.7; 8.8; 8.9. (section 6.3).
- 10.6. The management calculations procedures of tensile strength and elongation in accordance with EN13674-1 section 8.7.(section 6.4).
- 10.7. The Rails Acceptance Tests, from the last five years, carried out and signed by The Laboratory, approving the fulfillment of The Rail Grade R260 manufacture with the requirements of EN13674-1, section 9. (section 6.5).
- 10.8. A detailed description of the ultrasonic test method, including the separate ultrasonic procedure or The Rail end cut off process, including drawing showing the locations and dimensions of the artificial defects in The Rail head, web and foot. (section 7.2.4)
- 10.9. A detailed description of the automatic NDT test method, including drawing showing the locations and dimensions of the artificial defects in The Rail head and foot. (section 7.2.5.7).
- 10.10. The Laboratory certificate, approving its complains with one of the following requirements:
 - The Laboratory certified in accordance with ISO/IEC17025 in the field of steel quality testing.



or

- The Laboratory accredited by national laboratory accreditation authority in the field of steel quality testing.(section 8).

11. **LIST OF DOCUMENTS TO BE SUBMITTED WITH EVERY ORDER**

- 11.1. The Rails Acceptance Tests, carried out and signed by The Laboratory, approving the fulfillment of The Rail Grade R260 manufacture with the requirements of EN13674-1, section 9, and EN 10204, Type 3.1 or Type 3.2. (section 7).
- 11.2. The Rails mechanical properties and chemical composition inspection tests results, which conform with the requirements of EN13674-1, table 5(a); and table 5(b), and in additional EN 10204, Type 3.1; or Type 3.2. (section 7.2.1).
- 11.3. The tensile strength and elongation test results in compliance with the management calculations procedures (section 7.2.1).
- 11.4. The calibration certificates carried out by The Laboratory shall be submitted to The Inspector on request.

12. **PACKING**

- 12.1. Packing shall be loosed, provided that loading is carried out by means of a special device which enables the loading of 5 Rails at one time. Appropriate spaces shall be kept between The Rails on the ship in order to enable unloading with a similar device.



**TECHNICAL APPENDIX A – FISHPLATE BOLT HOLE POSITION –
IN THE RAIL WEB**

A.1 -- Rail Profile 60E2

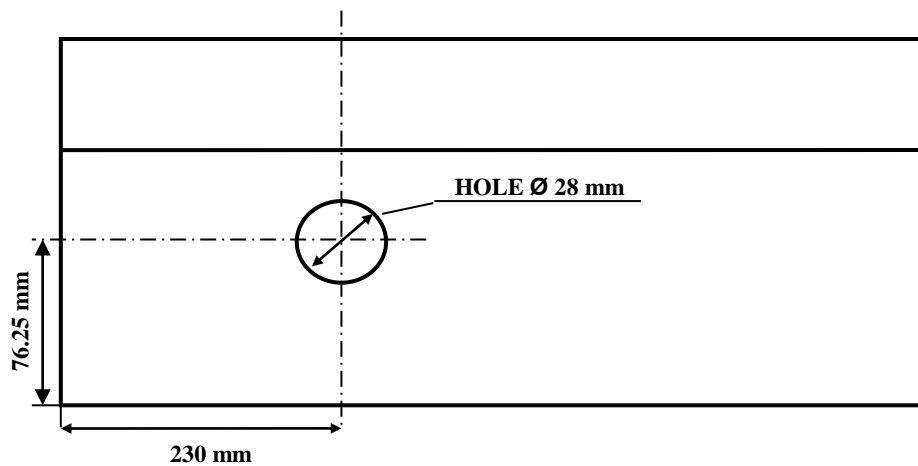
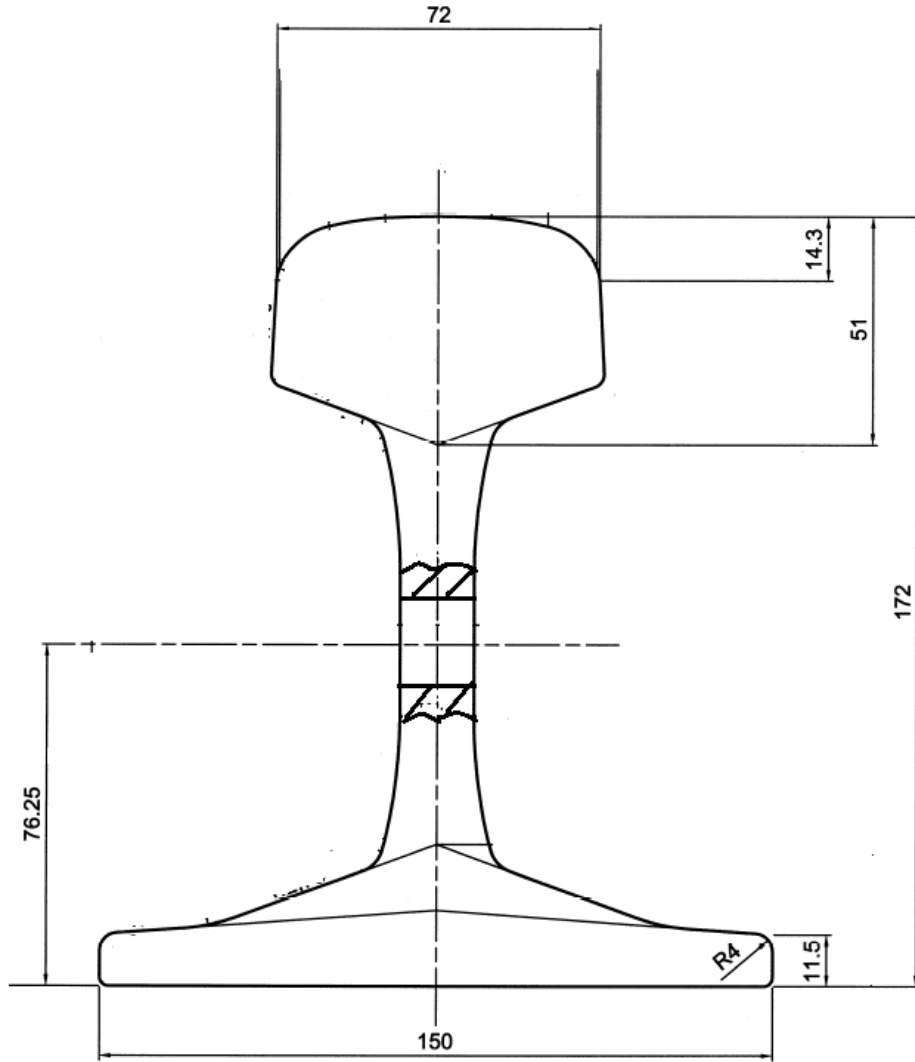

A.2 – Rail Profile 54E1

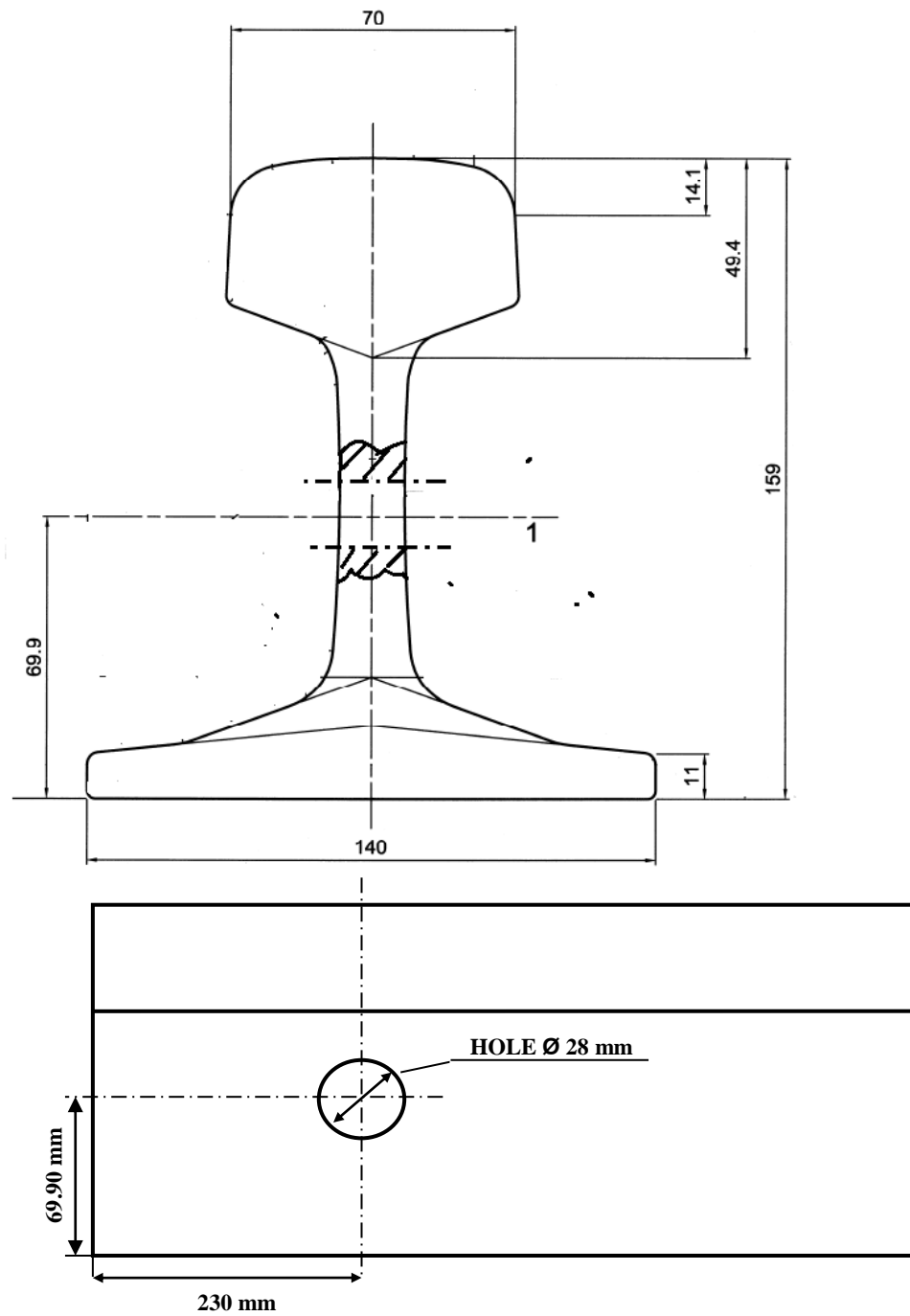



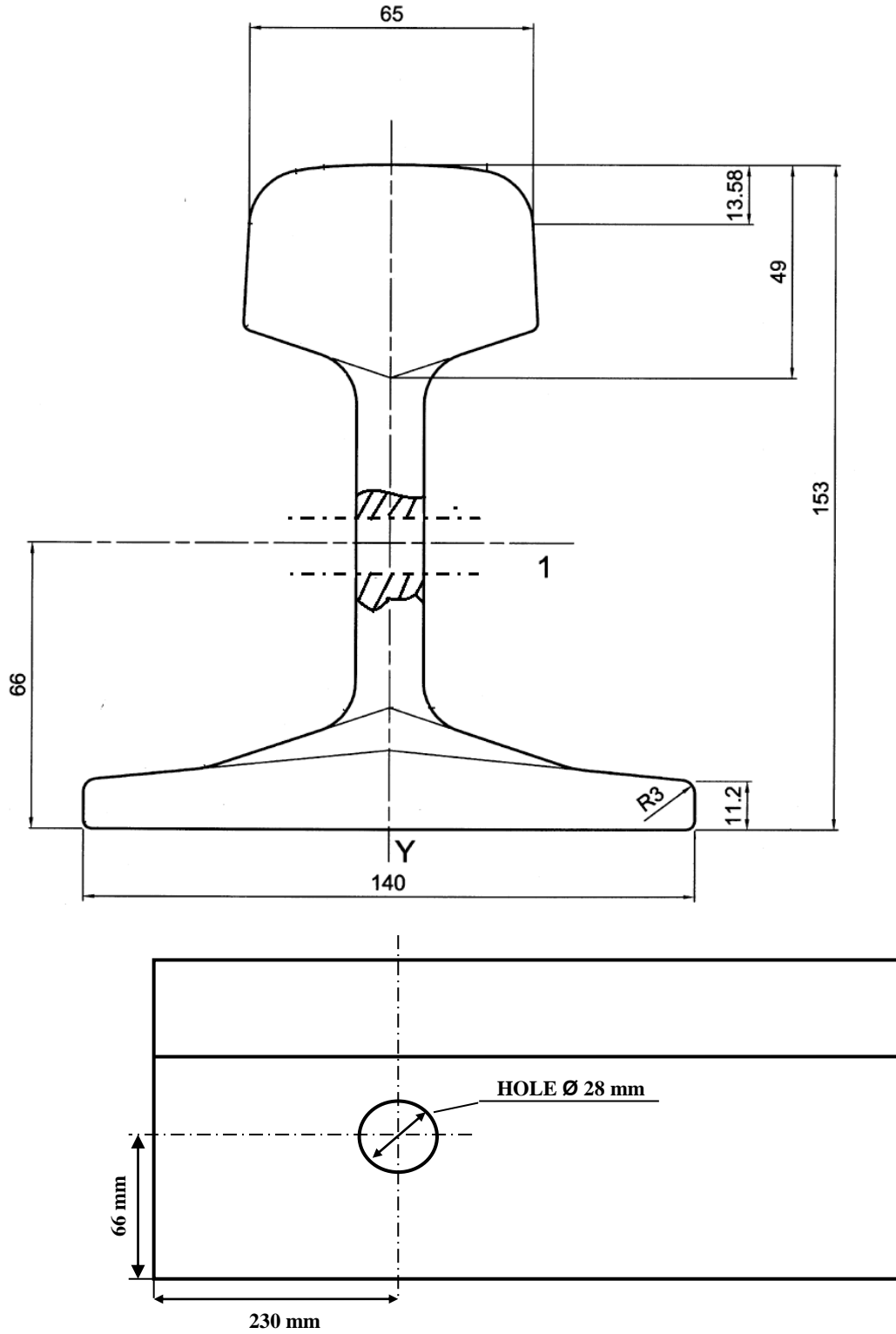



A.3 – Rail Profile 50E6

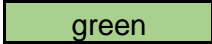

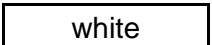

TECHNICAL APPENDIX B – COLOR MARK ON RAIL

<u>Rail</u>	<u>Profile Color</u>	<u>Grade Color</u>	<u>Color Mark on Rail</u>
60E2 R260	 green	+  white =>	
54E1 R260	 red	+  white =>	
50E6 R260	 yellow	+  white =>	